

HYDRAULIC CHUCK (SLIM)

DIN 69871-SK

HYDRAULIK SPANNFUTTER (SCHLANK)
 MANDRIN HYDRAULIQUE (MINCE)
 MANDRINI IDRAULICI (SOTTILE)
 PORTAHERRAMIENTAS HIDRAULICO (DELGADO)

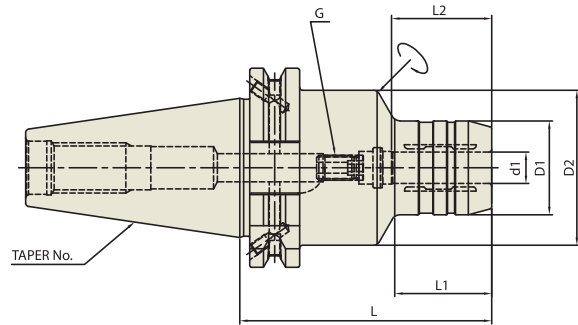

Unit : mm

TAPER No.	MODEL No.	EDP No.	d1	D1	D2	L	L1	L2	G	WEIGHT (kg)
30	SK30AD/B-HC6-70	P2770101	6	26	45	70	20	27	M5x0.8	0.65
	SK30AD/B-HC8-70	P2770110	8	28	45	70	20	27	M6x1.0	0.65
	SK30AD/B-HC10-75	P2770102	10	30	45	75	21	32	M8x1.0	0.73
	SK30AD/B-HC12-85	P2770111	12	32	45	85	40	37	M10x1.0	0.80
	SK30AD/B-HC14-85	P2770112	14	34	45	85	22	37	M10x1.0	0.80
	SK30AD/B-HC16-90	P2770113	16	38	45	90	50	42	M6x1.0	0.90
	SK30AD/B-HC18-90	P2770114	18	40	45	90	50	42	M10x1.0	0.90
	SK30AD/B-HC20-90	P2770115	20	42	45	90	50	42	M6x1.0	0.90
40	SK40AD/B-HC6-80.5	P2554017	6	26	49.5	80.5	30	27	M5x0.8	1.31
	SK40AD/B-HC6-110	P2554016	6	26	49.5	110	29.5	27	M5x0.8	1.76
	SK40AD/B-HC8-80.5	P2554025	8	28	49.5	80.5	30	27	M6x1.0	1.34
	SK40AD/B-HC8-110	P2770117	8	28	49.5	110	30	27	M6x1.0	1.76
	SK40AD/B-HC10-80.5	P2554004	10	30	49.5	80.5	31	32	M8x1.0	1.34
	SK40AD/B-HC10-110	P2554009	10	30	49.5	110	31	32	M8x1.0	1.76
	SK40AD/B-HC12-80.5	P2554011	12	32	49.5	80.5	31.5	37	M10x1.0	1.34
	SK40AD/B-HC12-110	P2554010	12	32	49.5	110	31.5	37	M10x1.0	1.76
	SK40AD/B-HC16-80.5	P2554013	16	38	49.5	80.5	33	42	M12x1.0	1.34
	SK40AD/B-HC16-110	P2554012	16	38	49.5	110	33	42	M12x1.0	1.76
	SK40AD/B-HC20-80.5	P2554015	20	42	49.5	80.5	34	42	M16x1.0	1.35
	SK40AD/B-HC20-110	P2554014	20	42	49.5	110	34	42	M16x1.0	1.78
	SK40AD/B-HC25-80.5	P2770103	25	55	66	80.5	22	48	M16x1.0	1.75
	SK40AD/B-HC32-110	P2770126	32	63	80	80.5	25.5	55	M16x1.0	2.60
50	SK50AD/B-HC6-80.5	P2770104	6	26	49.5	80.5	30	27	M5x0.8	3.00
	SK50AD/B-HC8-80.5	P2770116	8	28	49.5	80.5	30	27	M6x1.0	3.00
	SK50AD/B-HC10-80.5	P2770106	10	30	49.5	80.5	32	32	M8x1.0	3.00
	SK50AD/B-HC12-80.5	P2770118	12	32	49.5	80.5	35	37	M10x1.0	3.05
	SK50AD/B-HC16-80.5	P2770108	16	38	49.5	80.5	40	42	M12x1.0	3.10
	SK50AD/B-HC20-80.5	P2770119	20	42	49.5	80.5	40	42	M16x1.0	3.15

▶ CAT(ANSI B5.50) taper and Inch type products are available.