

**HYDRAULIC CHUCK (SLIM)**

**JIS B6339/  
MAS 403-BT**

HYDRAULIK SPANNFUTTER (SCHLANK)  
MANDRIN HYDRAULIQUE (MINCE)  
MANDRINI IDRAULICI (SOTTILE)  
PORTAHERRAMIENTAS HIDRAULICO (DELGADO)

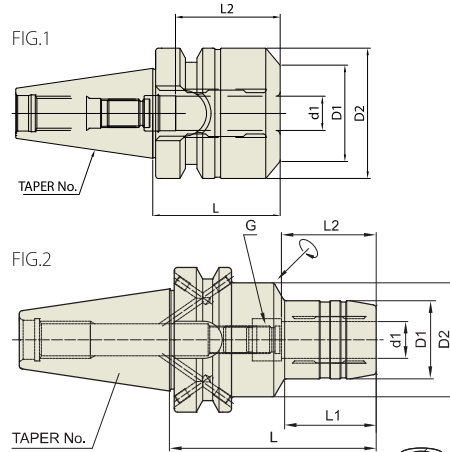

Collet  
Refer to page 43-46



Unit : mm

TAPER No.	MODEL No.	EDP No.	d1	D1	D2	L	L1	L2	G	FIG.	WEIGHT (kg)
30	BT30-HC6-45	P2770643A	6	46	46	45	-	27	M5x0.8	1	1.50
	BT30-HC8-45	P2770644A	8	46	46	45	-	27	M6x1.0	1	1.50
	BT30-HC10-45	P2770645A	10	46	46	45	-	32	M8x1.0	1	1.50
	BT30-HC12-45	P2770646A	12	46	46	45	-	37	M10x1.0	1	1.50
	BT30-HC16-45	P2770647A	16	46	46	45	-	42	M10x1.0	1	1.50
	BT30-HC20-60	P2770648A	20	53	53	60	-	42	M10x1.0	1	2.10
	BT30-HC6-70	P2770604A	6	26	44.5	70	29.5	27	M5x0.8	1	0.65
	BT30-HC8-70	P2770605A	8	28	44.5	70	30	27	M6x1.0	2	0.65
	BT30-HC10-75	P2770606A	10	30	44.5	75	31	32	M8x1.0	2	0.73
	BT30-HC12-85	P2770607A	12	32	45	85	45	37	M10x1.0	2	0.80
	BT30-HC14-85	P2770608A	14	34	45	85	45	37	M10x1.0	2	0.80
	BT30-HC16-90	P2770601A	16	38	45	90	50	42	M10x1.0	2	0.90
	BT30-HC18-90	P2770609A	18	40	45	90	50	42	M10x1.0	2	0.90
BT30-HC20-90	P2770602A	20	42	45	90	50	42	M6x1.0	2	0.90	
40	BT40AD/B-HC6-90	P2554003	6	26	44.5	90	43	27	M5x0.8	2	1.30
	BT40AD/B-HC8-90	P2554021	8	28	44.5	90	44.5	27	M6x1.0	2	1.30
	BT40AD/B-HC10-90	P2554005	10	30	44.5	90	44.5	32	M8x1.0	2	1.35
	BT40AD/B-HC12-90	P2554002	12	32	44.5	90	44.5	37	M10x1.0	2	1.35
	BT40AD/B-HC14-90	P2770610	14	34	44.5	90	44.5	37	M10x1.0	2	1.35
	BT40AD/B-HC16-90	P2554006	16	38	44.5	90	47.5	42	M12x1.0	2	1.40
	BT40AD/B-HC18-90	P2770611	18	40	44.5	90	47.5	42	M12x1.0	2	1.45
	BT40AD/B-HC20-90	P2554007	20	42	44.5	90	47.5	42	M16x1.0	2	1.50
	BT40AD/B-HC25-100	P2770641	25	50	60	100	47.5	48	M16x1.0	2	1.70
	BT40AD/B-HC32-105	P2770612	32	60	-	105	-	55	M16x1.0	2	2.10

▶ CAT(ANSI B5.50) taper and Inch type products are available.

HYDRAULIC CHUCK

SHRINK FIT HOLDER

ER COLLET CHUCK

END MILL HOLDER & SIDE LOCK ARBOR

SHELL MILL ARBOR

POWER MILLING CHUCK

MORSE TAPER ARBOR

SK SLIM CHUCK

SYNCHRO TAPPING CHUCK

ONE STEP TAPPING CHUCK

TAPPING ER CHUCK

TAPPING CHUCK

FACE MILL ARBOR

COPY MILL ARBOR & INDEXABLE DRILL HOLDER

NC DRILL CHUCK & OTHER TOOL HOLDERS

BORING SYSTEM

ACCESSORY & OTHERS

**HYDRAULIC CHUCK (SLIM)**

**JIS B6339/  
MAS 403-BT**

HYDRAULIK SPANNFUTTER (SCHLANK)  
MANDRIN HYDRAULIQUE (MINCE)  
MANDRINI IDRAULICI (SOTTILE)  
PORTAHERRAMIENTAS HIDRAULICO (DELGADO)

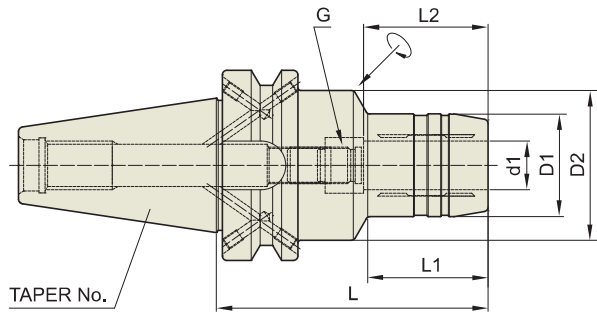

TAPER No.	MODEL No.	EDP No.	d1	D1	D2	L	L1	L2	G	WEIGHT (kg)
50	BT50AD/B-HC6-90	P2770613	6	26	44.5	90	34	27	M5×0.8	3.75
	BT50AD/B-HC6-120	P2770614	6	26	44.5	120	34	27	M5×0.8	4.10
	BT50AD/B-HC6-150	P2770615	6	26	44.5	150	34	27	M5×0.8	4.70
	BT50AD/B-HC8-90	P2770616	8	28	44.5	90	34	27	M6×1.0	3.75
	BT50AD/B-HC8-120	P2770617	8	28	44.5	120	34	27	M6×1.0	4.10
	BT50AD/B-HC8-150	P2770618	8	28	44.5	150	34	27	M6×1.0	4.10
	BT50AD/B-HC10-90	P2770619	10	30	44.5	90	34	32	M8×1.0	3.90
	BT50AD/B-HC10-120	P2770620	10	30	44.5	120	34	32	M8×1.0	4.30
	BT50AD/B-HC10-150	P2770621	10	30	44.5	150	34	32	M8×1.0	4.90
	BT50AD/B-HC12-90	P2770622	12	32	44.5	90	34	37	M10×1.0	3.90
	BT50AD/B-HC12-120	P2770623	12	32	44.5	120	34	37	M10×1.0	4.30
	BT50AD/B-HC12-150	P2770624	12	32	44.5	150	34	37	M10×1.0	4.90
	BT50AD/B-HC14-90	P2770625	14	34	44.5	90	34	37	M10×1.0	3.90
	BT50AD/B-HC14-120	P2770626	14	34	44.5	120	34	37	M10×1.0	4.30
	BT50AD/B-HC14-150	P2770627	14	34	44.5	150	34	37	M10×1.0	4.90
	BT50AD/B-HC16-90	P2770628	16	38	44.5	90	34	42	M12×1.0	4.00
	BT50AD/B-HC16-120	P2770629	16	38	44.5	120	34	42	M12×1.0	4.40
	BT50AD/B-HC16-150	P2770630	16	38	44.5	150	34	42	M12×1.0	5.00
	BT50AD/B-HC18-90	P2770631	18	40	44.5	90	34	42	M12×1.0	4.00
	BT50AD/B-HC18-120	P2770632	18	40	44.5	120	34	42	M12×1.0	4.40
	BT50AD/B-HC18-150	P2770633	18	40	44.5	150	34	42	M12×1.0	5.00
	BT50AD/B-HC20-90	P2770634	20	42	44.5	90	34	42	M16×1.0	4.00
	BT50AD/B-HC20-120	P2770635	20	42	44.5	120	34	42	M16×1.0	4.40
	BT50AD/B-HC20-150	P2770636	20	42	44.5	150	34	42	M16×1.0	5.00
	BT50AD/B-HC25-105	P2770637	25	57	63	105	52	48	M16×1.0	4.40
	BT50AD/B-HC25-150	P2770638	25	57	63	150	97	48	M16×1.0	5.60
	BT50AD/B-HC32-115	P2770639	32	64	75	115	62	55	M16×1.0	4.70
	BT50AD/B-HC32-150	P2770640	32	64	75	150	97	55	M16×1.0	6.00

► CAT(ANSI B5.50) taper and Inch type products are available.