

HYDRAULIC CHUCK (For MOLD and DIE)

**JIS B6339/
MAS 403-BT**

HYDRAULIK SPANNFUTTER FÜR DEN FORMENBAU
MANDRIN HYDRAULIQUE POUR MOULISTE
MANDRINI IDRAULICI PER STAMPAGGIO
PORTAHERRAMIENTAS HIDRAULICO PARA MOLDES

HYDRAULIC CHUCK

SHRINK FIT HOLDER

ER COLLET CHUCK

END MILL HOLDER & SIDE LOCK ARBOR

SHELL MILL ARBOR

POWER MILLING CHUCK

MORSE TAPER ARBOR

SK SLIM CHUCK

SYNCHRO TAPPING CHUCK

ONE STEP TAPPING CHUCK

TAPPING ER CHUCK

TAPPING CHUCK

FACE MILL ARBOR

COPY MILL ARBOR & INDEXABLE DRILL HOLDER

NC DRILL CHUCK & OTHER TOOL HOLDERS

BORING SYSTEM

ACCESSORY & OTHERS

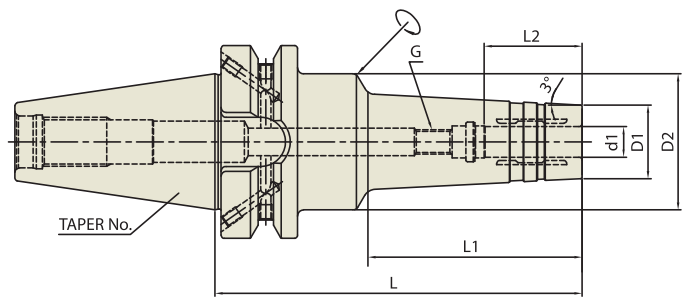

Collet
Refer to page 43-46

Unit : mm

TAPER No.	MODEL No.	EDP No.	d1	D1	D2	L	L1	L2	G	WEIGHT (kg)
40	BT40AD/B-HMC6-120	P2770903	6	20	44.5	120	70	27	M5×0.8	1.40
	BT40AD/B-HMC6-150	P2770904	6	20	44.5	150	100	27	M5×0.8	1.65
	BT40AD/B-HMC8-120	P2770905	8	22	44.5	120	70	27	M6×1.0	1.40
	BT40AD/B-HMC8-150	P2770906	8	22	44.5	150	100	27	M6×1.0	1.65
	BT40AD/B-HMC10-120	P2770907	10	24	44.5	120	70	32	M8×1.0	1.40
	BT40AD/B-HMC10-150	P2770908	10	24	44.5	150	100	32	M8×1.0	1.65
	BT40AD/B-HMC12-120	P2770901	12	25	44.5	120	70	37	M10×1.0	1.40
	BT40AD/B-HMC12-150	P2770909	12	25	44.5	150	100	37	M10×1.0	1.65
	BT40AD/B-HMC16-120	P2770910	16	32	44.5	120	70	42	M12×1.0	1.45
	BT40AD/B-HMC16-150	P2770911	16	32	44.5	150	100	42	M12×1.0	1.70
50	BT40AD/B-HMC20-120	P2770902	20	34	43.8	120	93	42	M16×1.0	1.50
	BT40AD/B-HMC20-150	P2770912	20	34	46.9	150	123	42	M16×1.0	1.80
	BT50AD/B-HMC6-150	P2770913	6	20	50	150	90	27	M5×0.8	4.70
	BT50AD/B-HMC8-150	P2770914	8	22	50	150	90	27	M6×1.0	4.70
	BT50AD/B-HMC10-150	P2770915	10	24	50	150	90	32	M8×1.0	4.70
	BT50AD/B-HMC12-150	P2770916	12	25	50	150	90	37	M10×1.0	4.70
	BT50AD/B-HMC16-150	P2770917	16	32	50	150	90	42	M12×1.0	4.90
	BT50AD/B-HMC20-150	P2770918	20	34	50	150	90	42	M16×1.0	5.00

▶ CAT(ANSI B5.50) taper and Inch type products are available.