

HYDRAULIC CHUCK (SLIM)

HYDRAULIK SPANNFUTTER (SCHLANK)
 MANDRIN HYDRAULIQUE (MINCE)
 MANDRINI IDRAULICI (SOTTILE)
 PORTAHERRAMIENTAS HIDRAULICO (DELGADO)

**CBT
(BT DUAL CONTACT)**

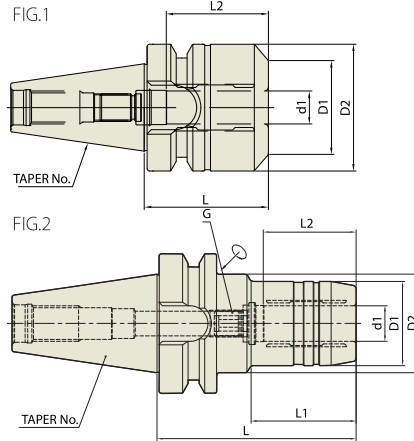

Collet
Refer to page 43-46

Unit : mm

TAPER No.	MODEL No.	EDP No.	d1	D1	D2	L	L1	L2	G	FIG.	WEIGHT (kg)
30	CBT30-HC6-45	P2770559	6	46	46	45	-	27	M5x0.8	1	1.50
	CBT30-HC8-45	P2770560	8	46	46	45	-	27	M6x1.0	1	1.50
	CBT30-HC10-45	P2770561	10	46	46	45	-	32	M8x1.0	1	1.50
	CBT30-HC12-45	P2770562	12	46	46	45	-	37	M10x1.0	1	1.50
	CBT30-HC16-45	P2770563	16	46	46	45	-	42	M10x1.0	1	1.50
	CBT30-HC20-60	P2770564	20	53	53	60	-	42	M10x1.0	1	2.10
	CBT30-HC6-70	P2770503	6	26	44.5	70	29.5	27	M5x0.8	2	0.65
	CBT30-HC8-70	P2770504	8	28	44.5	70	30	27	M6x1.0	2	0.65
	CBT30-HC10-75	P2770505	10	30	44.5	75	31	32	M8x1.0	2	0.73
	CBT30-HC12-85	P2770506	12	32	45	85	45	37	M10x1.0	2	0.80
	CBT30-HC14-85	P2770507	14	34	45	85	45	37	M10x1.0	2	0.80
	CBT30-HC16-90	P2770508	16	38	45	90	50	42	M10x1.0	2	0.90
	CBT30-HC18-90	P2770509	18	40	45	90	50	42	M10x1.0	2	0.90
CBT30-HC20-90	P2770510	20	42	45	90	50	42	M6x1.0	2	0.90	
40	CBT40-HC6-90	P2770511	6	26	44.5	90	43	27	M5x0.8	2	1.30
	CBT40-HC8-90	P2770512	8	28	44.5	90	44.5	27	M6x1.0	2	1.30
	CBT40-HC10-90	P2770513	10	30	44.5	90	44.5	32	M8x1.0	2	1.35
	CBT40-HC12-90	P2770501	12	32	44.5	90	44.5	37	M10x1.0	2	1.35
	CBT40-HC14-90	P2770514	14	34	44.5	90	44.5	37	M10x1.0	2	1.35
	CBT40-HC16-90	P2770515	16	38	44.5	90	47.5	42	M12x1.0	2	1.40
	CBT40-HC18-90	P2770516	18	40	44.5	90	47.5	42	M12x1.0	2	1.45
	CBT40-HC20-90	P2770502	20	42	44.5	90	47.5	42	M16x1.0	2	1.50
	CBT40-HC25-100	P2770517	25	50	60	100	47.5	48	M16x1.0	2	1.70
	CBT40-HC32-105	P2770518	32	60	60	105	-	55	M16x1.0	2	2.10

▶ NEXT PAGE

HYDRAULIC CHUCK

SHRINK FIT HOLDER

ER COLLET CHUCK

END MILL HOLDER & SIDE LOCK ARBOR

SHELL MILL ARBOR

POWER MILLING CHUCK

MORSE TAPER ARBOR

SK SLIM CHUCK

SYNCHRO TAPPING CHUCK

ONE STEP TAPPING CHUCK

TAPPING ER CHUCK

TAPPING CHUCK

FACE MILL ARBOR

COPY MILL ARBOR & INDEXABLE DRILL HOLDER

NC DRILL CHUCK & OTHER TOOL HOLDERS

BORING SYSTEM

ACCESSORY & OTHERS

HYDRAULIC CHUCK (SLIM)

CBT (BT DUAL CONTACT)

HYDRAULIK SPANNFUTTER (SCHLANK)
 MANDRIN HYDRAULIQUE (MINCE)
 MANDRINI IDRAULICI (SOTTILE)
 PORTAHERRAMIENTAS HIDRAULICO (DELGADO)

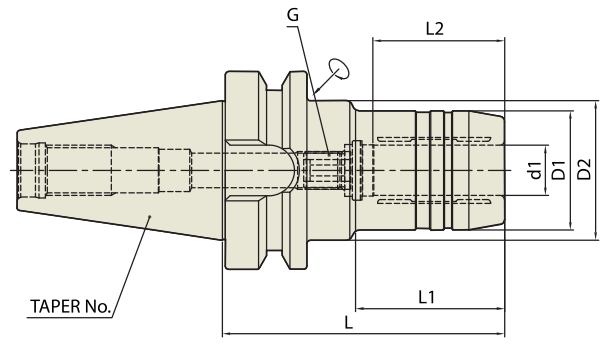

CBT AT3 2.5G 25,000 RPM (at 3D) ≤3µm AD

Collet Refer to page 43-46

TAPER No.	MODEL No.	EDP No.	d1	D1	D2	L	L1	L2	G	WEIGHT (kg)
50	CBT50-HC6-90	P2770519	6	26	44.5	90	34	27	M5×0.8	3.75
	CBT50-HC6-120	P2770520	6	26	44.5	120	34	27	M5×0.8	4.10
	CBT50-HC6-150	P2770521	6	26	44.5	150	34	27	M5×0.8	4.70
	CBT50-HC8-90	P2770522	8	28	44.5	90	34	27	M6×1.0	3.75
	CBT50-HC8-120	P2770523	8	28	44.5	120	34	27	M6×1.0	4.10
	CBT50-HC8-150	P2770524	8	28	44.5	150	34	27	M6×1.0	4.10
	CBT50-HC10-90	P2770525	10	30	44.5	90	34	32	M8×1.0	3.90
	CBT50-HC10-120	P2770526	10	30	44.5	120	34	32	M8×1.0	4.30
	CBT50-HC10-150	P2770527	10	30	44.5	150	34	32	M8×1.0	4.90
	CBT50-HC12-90	P2770528	12	32	44.5	90	34	37	M10×1.0	3.90
	CBT50-HC12-120	P2770529	12	32	44.5	120	34	37	M10×1.0	4.30
	CBT50-HC12-150	P2770530	12	32	44.5	150	34	37	M10×1.0	4.90
	CBT50-HC14-90	P2770531	14	34	44.5	90	34	37	M10×1.0	3.90
	CBT50-HC14-120	P2770532	14	34	44.5	120	34	37	M10×1.0	4.30
	CBT50-HC14-150	P2770533	14	34	44.5	150	34	37	M10×1.0	4.90
	CBT50-HC16-90	P2770534	16	38	44.5	90	34	42	M12×1.0	4.00
	CBT50-HC16-120	P2770535	16	38	44.5	120	34	42	M12×1.0	4.40
	CBT50-HC16-150	P2770536	16	38	44.5	150	34	42	M12×1.0	5.00
	CBT50-HC18-90	P2770537	18	40	44.5	90	34	42	M12×1.0	4.00
	CBT50-HC18-120	P2770538	18	40	44.5	120	34	42	M12×1.0	4.40
	CBT50-HC18-150	P2770539	18	40	44.5	150	34	42	M12×1.0	5.00
	CBT50-HC20-90	P2770540	20	42	44.5	90	34	42	M16×1.0	4.00
	CBT50-HC20-120	P2770541	20	42	44.5	120	34	42	M16×1.0	4.40
	CBT50-HC20-150	P2770542	20	42	44.5	150	34	42	M16×1.0	5.00
	CBT50-HC25-105	P2770543	25	57	63	105	52	48	M16×1.0	4.40
	CBT50-HC25-150	P2770544	25	57	63	150	97	48	M16×1.0	5.60
	CBT50-HC32-115	P2770545	32	64	75	115	62	55	M16×1.0	4.70
	CBT50-HC32-150	P2770546	32	64	75	150	97	55	M16×1.0	6.00