



SHRINK FIT HOLDER

SFH

SHRINK FIT HOLDER

DIN 69871-SK

SCHRUMPFUTTER
MANDRIN DE FRETTAGE
MADRINI PER CALLETAMENTO A CALDO
PORTAHERRAMIENTAS DE COMPRESION POR CALOR

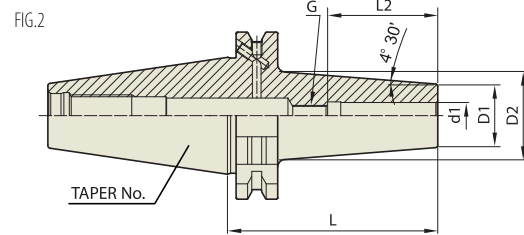
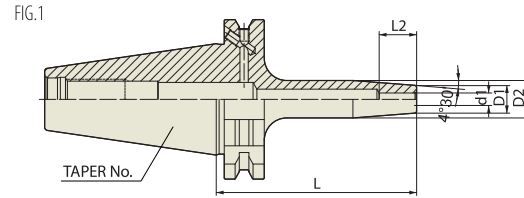

Unit : mm

TAPER No.	MODEL No.	EDP No.	d1	D1	D2	L	L2	G	FIG.	WEIGHT (kg)
30	SK30AD/B-SFH3-60	P2771308	3	11	15	60	10	-	1	0.40
	SK30AD/B-SFH4-60	P2771309	4	11	15	60	12	-	1	0.40
	SK30AD/B-SFH5-60	P2771310	5	11	15	60	15	-	1	0.40
	SK30AD/B-SFH6-60	P2771311	6	21	27	60	36	M5×0.8	2	0.40
	SK30AD/B-SFH8-60	P2771312	8	21	27	60	36	M6×1.0	2	0.40
	SK30AD/B-SFH10-80	P2771313	10	24	32	80	42	M8×1.0	2	0.40
	SK30AD/B-SFH12-80	P2771314	12	24	32	80	47	M10×1.0	2	0.42
	SK30AD/B-SFH14-80	P2771315	14	27	34	80	47	M10×1.0	2	-
	SK30AD/B-SFH16-80	P2771316	16	27	34	80	50	M12×1.0	2	0.42
	SK30AD/B-SFH18-80	P2771317	18	33	42	80	50	M12×1.0	2	-
SK30AD/B-SFH20-90	P2771318	20	33	42	90	52	M16×1.0	2	0.44	
40	SK40AD/B-SFH3-80	P2771301	3	11	15	80	10	-	1	1.00
	SK40AD/B-SFH4-80	P2771302	4	11	15	80	12	-	1	1.00
	SK40AD/B-SFH5-80	P2771303	5	11	15	80	15	-	1	1.00
	SK40AD/B-SFH6-80	P2554058	6	21	27	80	36	M5×0.8	2	1.10
	SK40AD/B-SFH6-160	P2771304	6	21	27	160	36	M5×0.8	2	1.15
	SK40AD/B-SFH8-80	P2600009	8	21	27	80	36	M6×1.0	2	1.11
	SK40AD/B-SFH8-160	P2771305	8	21	27	160	36	M6×1.0	2	1.15
	SK40AD/B-SFH10-80	P2554052	10	24	32	80	42	M8×1.0	2	1.10
	SK40AD/B-SFH10-160	P2771306	10	24	32	160	42	M8×1.0	2	1.15
	SK40AD/B-SFH12-80	P2600008	12	24	32	80	47	M10×1.0	2	1.10
	SK40AD/B-SFH12-160	P2771307	12	24	32	160	47	M10×1.0	2	1.15
	SK40AD/B-SFH14-80	P2771319	14	27	34	80	47	M10×1.0	2	1.20
	SK40AD/B-SFH14-160	P2771320	14	27	34	160	47	M10×1.0	2	1.50
	SK40AD/B-SFH16-80	P2554054	16	27	34	80	50	M12×1.0	2	1.20
	SK40AD/B-SFH16-160	P2554053	16	27	34	160	50	M12×1.0	2	1.50
	SK40AD/B-SFH18-80	P2771321	18	33	42	80	50	M12×1.0	2	1.30
	SK40AD/B-SFH18-160	P2771322	18	33	42	160	50	M12×1.0	2	1.60
	SK40AD/B-SFH20-80	P2554056	20	33	42	80	52	M16×1.0	2	1.40
	SK40AD/B-SFH20-160	P2554055	20	33	42	160	52	M16×1.0	2	1.70
	SK40AD/B-SFH25-90	P2771323	25	44	53	90	58	M16×1.0	2	1.70
SK40AD/B-SFH25-160	P2771324	25	44	53	160	58	M16×1.0	2	2.00	

▶ CAT(ANSI B5.50) taper and Inch type products are available.
▶ Without balancing screw.

▶ NEXT PAGE

SHRINK FIT HOLDER

DIN 69871-SK

SCHRUMPFUTTER
MANDRIN DE FRETTAGE
MADRINI PER CALLETAMENTO A CALDO
PORTAHERRAMIENTAS DE COMPRESION POR CALOR

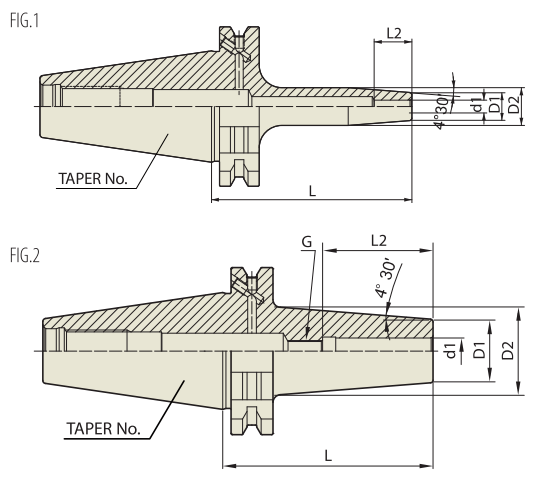

										Unit : mm
TAPER No.	MODEL No.	EDP No.	d1	D1	D2	L	L2	G	FIG.	WEIGHT (kg)
50	SK50AD/B-SFH3-80	P2771325	3	11	15	100	10	-	1	1.50
	SK50AD/B-SFH4-80	P2771326	4	11	15	100	12	-	1	1.50
	SK50AD/B-SFH5-80	P2771327	5	11	15	100	15	-	1	1.50
	SK50AD/B-SFH6-80	P2771328	6	21	27	80	36	M5×0.8	2	1.50
	SK50AD/B-SFH6-160	P2771329	6	21	27	160	36	M5×0.8	2	2.00
	SK50AD/B-SFH8-80	P2760010	8	21	27	80	36	M6×1.0	2	1.50
	SK50AD/B-SFH8-160	P2760015	8	21	27	160	36	M6×1.0	2	2.00
	SK50AD/B-SFH10-80	P2761010	10	24	32	80	42	M8×1.0	2	1.50
	SK50AD/B-SFH10-160	P2761015	10	24	32	160	42	M8×1.0	2	2.00
	SK50AD/B-SFH12-80	P2762010	12	24	32	80	47	M10×1.0	2	1.50
	SK50AD/B-SFH12-160	P2762015	12	24	32	160	47	M10×1.0	2	2.00
	SK50AD/B-SFH14-80	P2763010	14	27	34	80	47	M10×1.0	2	1.60
	SK50AD/B-SFH14-160	P2763015	14	27	34	160	47	M10×1.0	2	2.10
	SK50AD/B-SFH16-80	P2764010	16	27	34	80	50	M12×1.0	2	1.60
	SK50AD/B-SFH16-160	P2764015	16	27	34	160	50	M12×1.0	2	2.10
	SK50AD/B-SFH18-80	P2765010	18	33	42	80	50	M12×1.0	2	1.60
	SK50AD/B-SFH18-160	P2765015	18	33	42	160	50	M12×1.0	2	2.00
	SK50AD/B-SFH20-80	P2766010	20	33	42	80	52	M16×1.0	2	1.80
	SK50AD/B-SFH20-160	P2766015	20	33	42	160	52	M16×1.0	2	2.20
	SK50AD/B-SFH25-90	P2771330	25	44	53	90	58	M16×1.0	2	2.00
SK50AD/B-SFH25-160	P2771331	25	44	53	160	58	M16×1.0	2	2.40	

- ▶ CAT(ANSI B5.50) taper and Inch type products are available.
- ▶ Without balancing screw.