

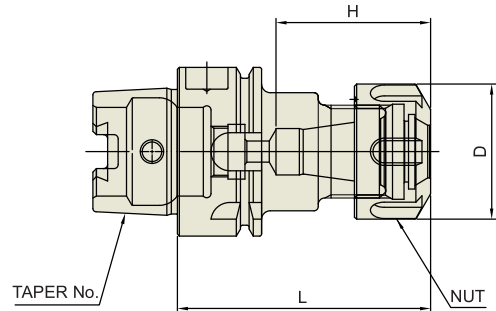

ER COLLET CHUCK

FRÄSERSPANNFUTTER - ER
 MANDRIN À PINCES - ER
 MANDRINO PORTA PINZE - ER
 PORTAPINZAS - ER

**DIN 69893/
 ISO 12164-1-HSK FORM A**

 ER Collet
 Refer to page 103-109

 ER nut, Sealing disk and Spanner
 Refer to page 110-115

◆ Standard Type

								Unit : mm	
TAPER No.	MODEL No.	EDP No.	CLAMPING RANGE	L	D	H	NUT / COLLET	WEIGHT (kg)	
32A	HSK32A-ER11-50	P2774908	0.5 - 7.0	50	19	28.6	ER11	0.18	
	HSK32A-ER16-60	P2774909	0.5 - 10.0	60	28	36.6	ER16	0.21	
40A	HSK40A-ER11-60	P2774910	0.5 - 7.0	60	19	28.6	ER11	0.40	
	HSK40A-ER16-60	P2774911	0.5 - 10.0	60	28	36.6	ER16	0.50	
	HSK40A-ER20-70	P2774912	0.5 - 13.0	70	34	44.5	ER20	0.80	

◆ Slim Type

								Unit : mm	
TAPER No.	MODEL No.	EDP No.	CLAMPING RANGE	L	D	H	NUT / COLLET	WEIGHT (kg)	
32A	HSK32A-ER8M-40	P2774913	0.5 - 5.0	40	12	21	ER8M	0.18	
	HSK32A-ER11M-40	P2774914	0.5 - 7.0	40	16	23	ER11M	0.18	
	HSK32A-ER16M-60	P2774915	0.5 - 10.0	60	22	38	ER16M	0.21	
	HSK32A-ER20M-60	P2774916	0.5 - 13.0	60	28	39.5	ER20M	0.21	
40A	HSK40A-ER11M-75	P2774917	0.5 - 7.0	75	16	29.5	ER11M	0.40	
	HSK40A-ER16M-80	P2774918	0.5 - 10.0	80	22	38	ER16M	0.50	
	HSK40A-ER20M-80	P2774919	0.5 - 13.0	80	28	44.5	ER20M	0.70	
	HSK40A-ER25M-80	P2774920	1.0 - 16.0	80	35	52	ER25M	0.80	