



SHRINK FIT HOLDER

SFH

SHRINK FIT HOLDER

SCHRUMPFUTTER
 MANDRIN DE FRETTAGE
 MADRINI PER CALLETAMENTO A CALDO
 PORTAHERRAMIENTAS DE COMPRESION POR CALOR

CBT (BT DUAL CONTACT)

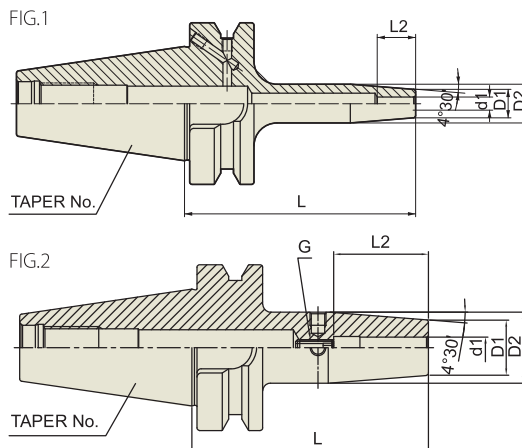

Unit : mm

TAPER No.	MODEL No.	EDP No.	d1	D1	D2	L	L2	G	FIG.	WEIGHT (kg)
30	CBT30-SFH3-60	P2771505	3	11	15	60	10	-	1	0.40
	CBT30-SFH4-60	P2771506	4	11	15	60	12	-	1	0.40
	CBT30-SFH5-60	P2771507	5	11	15	60	15	-	1	0.40
	CBT30-SFH6-60	P2771508	6	21	27	60	36	M5×0.8	2	0.40
	CBT30-SFH8-60	P2771509	8	21	27	60	36	M6×1.0	2	0.40
	CBT30-SFH10-80	P2771510	10	24	32	80	41	M8×1.0	2	0.40
	CBT30-SFH12-80	P2771511	12	24	32	80	48	M10×1.0	2	0.42
	CBT30-SFH14-80	P2771512	14	27	34	80	48	M10×1.0	2	
	CBT30-SFH16-80	P2771513	16	27	34	80	51	M12×1.0	2	0.42
	CBT30-SFH18-80	P2771514	18	27	34	80	51	M12×1.0	2	
40	CBT30-SFH20-90	P2771515	20	33	42	90	53	M16×1.0	2	0.44
	CBT40-SFH3-90	P2771516	3	11	15	90	10	-	1	1.00
	CBT40-SFH4-90	P2771517	4	11	15	90	12	-	1	1.00
	CBT40-SFH5-90	P2771518	5	11	15	90	23	-	1	1.00
	CBT40-SFH6-90	P2771519	6	21	27	90	36	M5×0.8	2	1.10
	CBT40-SFH6-160	P2771520	6	21	27	160	36	M5×0.8	2	1.15
	CBT40-SFH8-90	P2771501	8	21	27	90	36	M6×1.0	2	1.11
	CBT40-SFH8-160	P2771521	8	21	27	160	36	M6×1.0	2	1.15
	CBT40-SFH10-90	P2771502	10	24	32	90	41	M8×1.0	2	1.10
	CBT40-SFH10-160	P2771522	10	24	32	160	41	M8×1.0	2	1.15
	CBT40-SFH12-90	P2771503	12	24	32	90	47	M10×1.0	2	1.10
	CBT40-SFH12-160	P2771523	12	24	32	160	47	M10×1.0	2	1.15
	CBT40-SFH14-90	P2771524	14	27	34	90	47	M10×1.0	2	1.20
	CBT40-SFH14-160	P2771525	14	27	34	160	47	M10×1.0	2	1.50
	CBT40-SFH16-90	P2771526	16	27	34	90	50	M12×1.0	2	1.20
	CBT40-SFH16-160	P2771527	16	27	34	160	50	M12×1.0	2	1.50
	CBT40-SFH18-90	P2771528	18	33	42	90	50	M12×1.0	2	1.30
	CBT40-SFH18-160	P2771529	18	33	42	160	50	M12×1.0	2	1.60
	CBT40-SFH20-90	P2771504	20	33	42	90	52	M16×1.0	2	1.40
	CBT40-SFH20-160	P2771530	20	33	42	160	52	M16×1.0	2	1.70
	CBT40-SFH25-100	P2771531	25	44	53	100	58	M16×1.0	2	1.70
	CBT40-SFH25-160	P2771532	25	44	53	160	58	M16×1.0	2	2.00

▶ Without balancing screw.

SHRINK FIT HOLDER

SFH

SHRINK FIT HOLDER

SCHRUMPFUTTER
 MANDRIN DE FRETAGE
 MADRINI PER CALLETAMENTO A CALDO
 PORTAHERRAMIENTAS DE COMPRESION POR CALOR

CBT
 (BT DUAL CONTACT)

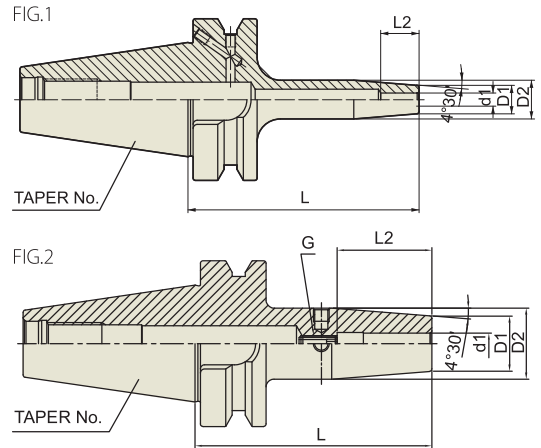

Unit : mm

TAPER No.	MODEL No.	EDP No.	d1	D1	D2	L	L2	G	FIG.	WEIGHT (kg)
50	CBT50-SFH3-100	P2771533	3	11	15	100	10	-	1	1.50
	CBT50-SFH4-100	P2771534	4	11	15	100	12	-	1	1.50
	CBT50-SFH5-100	P2771535	5	11	15	100	15	-	1	1.50
	CBT50-SFH6-100	P2771536	6	21	27	100	36	M5×0.8	2	1.50
	CBT50-SFH6-160	P2771537	6	21	27	160	36	M5×0.8	2	2.00
	CBT50-SFH8-100	P2771538	8	21	27	100	36	M6×1.0	2	1.50
	CBT50-SFH8-160	P2771539	8	21	27	160	36	M6×1.0	2	2.00
	CBT50-SFH10-100	P2771540	10	24	32	100	42	M8×1.0	2	1.50
	CBT50-SFH10-160	P2771541	10	24	32	160	42	M8×1.0	2	2.00
	CBT50-SFH12-100	P2771542	12	24	32	100	47	M10×1.0	2	1.50
	CBT50-SFH12-160	P2771543	12	24	32	160	47	M10×1.0	2	2.00
	CBT50-SFH14-100	P2771544	14	27	34	100	47	M10×1.0	2	1.60
	CBT50-SFH14-160	P2771545	14	27	34	160	47	M10×1.0	2	2.10
	CBT50-SFH16-100	P2771546	16	27	34	100	50	M12×1.0	2	1.60
	CBT50-SFH16-160	P2771547	16	27	34	160	50	M12×1.0	2	2.10
	CBT50-SFH18-100	P2771548	18	33	42	100	50	M12×1.0	2	1.60
	CBT50-SFH18-160	P2771549	18	33	42	160	50	M12×1.0	2	2.00
	CBT50-SFH20-100	P2771550	20	33	42	100	52	M16×1.0	2	1.80
	CBT50-SFH20-160	P2771551	20	33	42	160	52	M16×1.0	2	2.20
	CBT50-SFH25-100	P2771552	25	44	53	100	58	M16×1.0	2	2.00
CBT50-SFH25-160	P2771553	25	44	53	160	58	M16×1.0	2	2.40	

► Without balancing screw.