



SHRINK FIT HOLDER

SFH

SHRINK FIT HOLDER

SCHRUMPFUTTER
MANDRIN DE FRETTAGE
MADRINI PER CALLETAMENTO A CALDO
PORTAHERRAMIENTAS DE COMPRESION POR CALOR

JIS B6339/ MAS 403-BT

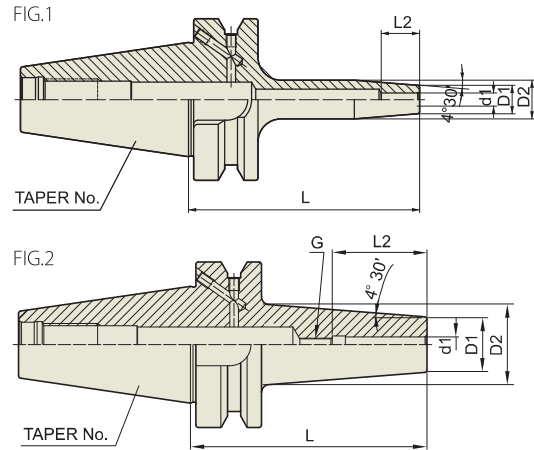

Unit : mm

TAPER No.	MODEL No.	EDP No.	d1	D1	D2	L	L2	G	FIG.	WEIGHT (kg)
30	BT30AD/B-SFH3-60	P2776703	3	11	15	60	10	-	1	0.40
	BT30AD/B-SFH4-60	P2776702	4	11	15	60	12	-	1	0.40
	BT30AD/B-SFH5-60	P2776704	5	11	15	60	15	-	1	0.40
	BT30AD/B-SFH6-60	P2776701	6	21	27	60	36	M5×0.8	2	0.40
	BT30AD/B-SFH8-60	P2776705	8	21	27	60	36	M6×1.0	2	0.40
	BT30AD/B-SFH10-80	P2776706	10	24	32	80	42	M8×1.0	2	0.40
	BT30AD/B-SFH12-80	P2776707	12	24	32	80	47	M10×1.0	2	0.42
	BT30AD/B-SFH14-80	P2776708	14	27	34	80	47	M10×1.0	2	
	BT30AD/B-SFH16-80	P2776709	16	27	34	80	50	M12×1.0	2	0.42
	BT30AD/B-SFH18-80	P2776710	18	33	42	80	50	M12×1.0	2	
40	BT30AD/B-SFH20-90	P2776711	20	33	42	90	52	M16×1.0	2	0.44
	BT40AD/B-SFH3-90	P2776712	3	11	15	90	10	-	1	1.00
	BT40AD/B-SFH4-90	P2776713	4	11	15	90	12	-	1	1.00
	BT40AD/B-SFH5-90	P2776714	5	11	15	90	15	-	1	1.00
	BT40AD/B-SFH6-90	P2771601	6	21	27	90	36	M5×0.8	2	1.10
	BT40AD/B-SFH6-160	P2771602	6	21	27	160	36	M5×0.8	2	1.15
	BT40AD/B-SFH8-90	P2771603	8	21	27	90	36	M6×1.0	2	1.11
	BT40AD/B-SFH8-160	P2771604	8	21	27	160	36	M6×1.0	2	1.15
	BT40AD/B-SFH10-90	P2771605	10	24	32	90	42	M8×1.0	2	1.10
	BT40AD/B-SFH10-160	P2771606	10	24	32	160	42	M8×1.0	2	1.15
	BT40AD/B-SFH12-90	P2771607	12	24	32	90	47	M10×1.0	2	1.10
	BT40AD/B-SFH12-160	P2771608	12	24	32	160	47	M10×1.0	2	1.15
	BT40AD/B-SFH14-90	P2771611	14	27	34	90	47	M10×1.0	2	1.20
	BT40AD/B-SFH14-160	P2771612	14	27	34	160	47	M10×1.0	2	1.50
	BT40AD/B-SFH16-90	P2771609	16	27	34	90	50	M12×1.0	2	1.20
	BT40AD/B-SFH16-160	P2771610	16	27	34	160	50	M12×1.0	2	1.50
	BT40AD/B-SFH18-90	P2771613	18	33	42	90	50	M12×1.0	2	1.30
	BT40AD/B-SFH18-160	P2771614	18	33	42	160	50	M12×1.0	2	1.60
BT40AD/B-SFH20-90	P2771615	20	33	42	90	52	M16×1.0	2	1.40	
BT40AD/B-SFH20-160	P2771616	20	33	42	160	52	M16×1.0	2	1.70	
BT40AD/B-SFH25-100	P2771617	25	44	53	100	58	M16×1.0	2	1.70	
BT40AD/B-SFH25-160	P2771618	25	44	53	160	58	M16×1.0	2	2.00	

▶ CAT(ANSI B5.50) taper and Inch type products are available.
▶ Without balancing screw.

SHRINK FIT HOLDER

**JIS B6339/
MAS 403-BT**

SCHRUMPFUTTER
MANDRIN DE FRETAGE
MADRINI PER CALLETAMENTO A CALDO
PORTAHERRAMIENTAS DE COMPRESION POR CALOR

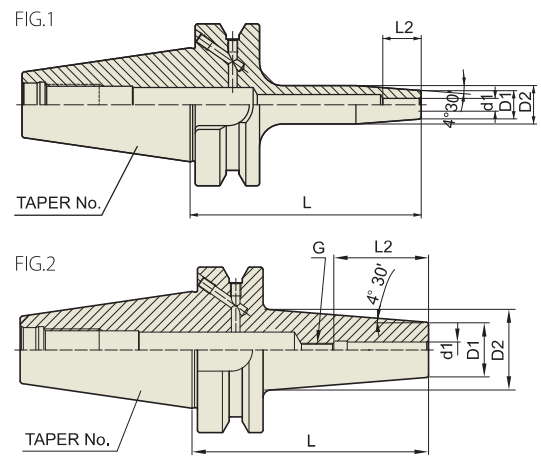

Unit : mm

TAPER No.	MODEL No.	EDP No.	d1	D1	D2	L	L2	G	FIG.	WEIGHT (kg)
50	BT50AD/B-SFH3-100	P2771619	3	11	15	100	10	-	1	1.50
	BT50AD/B-SFH4-100	P2771620	4	11	15	100	12	-	1	1.50
	BT50AD/B-SFH5-100	P2771621	5	11	15	100	15	-	1	1.50
	BT50AD/B-SFH6-100	P2771622	6	21	27	100	36	M5×0.8	2	1.50
	BT50AD/B-SFH6-160	P2771623	6	21	27	160	36	M5×0.8	2	2.00
	BT50AD/B-SFH8-100	P2771624	8	21	27	100	36	M6×1.0	2	1.50
	BT50AD/B-SFH8-160	P2771625	8	21	27	160	36	M6×1.0	2	2.00
	BT50AD/B-SFH10-100	P2771626	10	24	32	100	42	M8×1.0	2	1.50
	BT50AD/B-SFH10-160	P2771627	10	24	32	160	42	M8×1.0	2	2.00
	BT50AD/B-SFH12-100	P2771628	12	24	32	100	47	M10×1.0	2	1.50
	BT50AD/B-SFH12-160	P2771629	12	24	32	160	47	M10×1.0	2	2.00
	BT50AD/B-SFH14-100	P2771630	14	27	34	100	47	M10×1.0	2	1.60
	BT50AD/B-SFH14-160	P2771631	14	27	34	160	47	M10×1.0	2	2.10
	BT50AD/B-SFH16-100	P2771632	16	27	34	100	50	M12×1.0	2	1.60
	BT50AD/B-SFH16-160	P2771633	16	27	34	160	50	M12×1.0	2	2.10
	BT50AD/B-SFH18-100	P2771634	18	33	42	100	50	M12×1.0	2	1.60
	BT50AD/B-SFH18-160	P2771635	18	33	42	160	50	M12×1.0	2	2.00
	BT50AD/B-SFH20-100	P2771636	20	33	42	100	52	M16×1.0	2	1.80
	BT50AD/B-SFH20-160	P2771637	20	33	42	160	52	M16×1.0	2	2.20
	BT50AD/B-SFH25-100	P2771638	25	44	53	100	58	M16×1.0	2	2.00
BT50AD/B-SFH25-160	P2771639	25	44	53	160	58	M16×1.0	2	2.40	

- ▶ CAT(ANSI B5.50) taper and Inch type products are available.
- ▶ Without balancing screw.